

ANDROID-ARM BASED SWITCH CONTROL USING SMART PHONE

¹Santosh ET, ²Vidhya V, ³Satish Kumar R

Department of Electronics & Telecommunication Engineering
Rajiv Gandhi College of Engineering, Chennai, India

¹etsant.18@gmail.com, ²vidhu2992@gmail.com, ³satzkumr7@yahoo.com

Abstract

The main idea behind this proposal is to provide an ease off access to the user by providing full control over his/her entire home. Due to modern city life we never find time to check any of our electric appliances, switches, thermostats, air conditioners and so on, whether they are regularly switched off when not in use. We are not even aware whether our doors are locked, before we leave to work. This results in Energy wastage, security risk, and eventually leads to stress.

In our method we suggest an all in one method to control our appliances by using a simple android mobile phone. Though there are many home automation techniques which are operated in considerably high power and carrying a remote is necessary. We suggest an ease off method by using an Android phone with minimal power specifications.

The main purpose of this concept is to conserve energy just by means of using his/her Android Smart phone and to provide an easy access in the process to the user.

I. INTRODUCTION:

A typical ARM (Advanced RISC Machine) processor is one which controls its hardware peripherals using programming techniques. The programming concept is based on reduced instruction set computing (RISC), by means of which the hardware can be controlled by user program.

We thought of giving the ARM processor an ANDROID operating system controlled instruction sets, due to its Open source license agreement. The main advantage of an android is that every hardware peripherals can be individually programmed according to the user.

By developing an android application, it can be installed in the smart phone and the user interface generates certain codes which can be fed into the ARM processor. If this ARM processor is connected to the main circuit board, then the user can control all his appliances, through 2G/3G data connections.

II. ARM PROCESSOR:

A typical The ARM7TDMI-S is a general purpose 32-bit microprocessor, which offers high performance and very low power consumption. The ARM architecture is based on Reduced Instruction Set Computer (RISC) principles, and the instruction set and related decode mechanism are much simpler than those of micro programmed Complex Instruction Set Computers. This simplicity results in a high instruction throughput and impressive real-time interrupt response from a small and cost-effective processor core.

Pipeline techniques are employed so that all parts of the processing and memory systems can operate continuously. Typically, while one instruction is being executed, its successor is being decoded, and a third instruction is being fetched from memory.

The ARM7TDMI-S processor also employs a unique architectural strategy known as THUMB, which makes it ideally suited to high-volume applications with memory restrictions, or applications where code density is an issue.

ARM7TDMI-S can be operated in two modes

- The standard 32-bit ARM instruction set.
- A 16-bit THUMB instruction set.

Depending upon the user need either mode can be used. In our proposal it is operated in 32 bit mode.

III. BLOCK DIAGRAM:

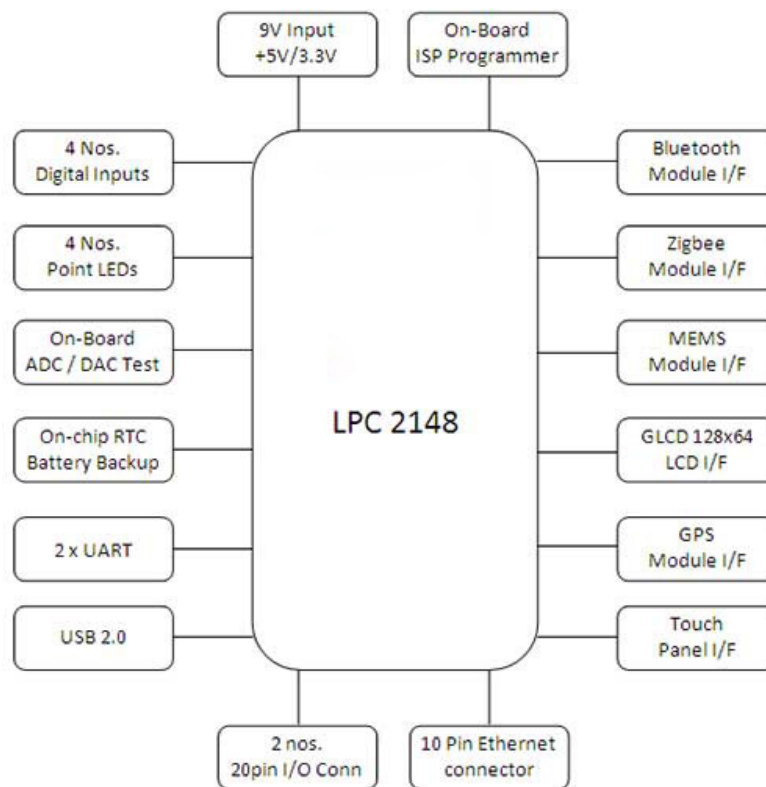

Fig 1.1 LPC2148 Architecture

Fig 1.1 shows the general block diagram of ARM&TDMI-S processor. Here for our purpose we use LPC 2148 NXP IC for controlling the relay circuits and switches.

IV. ANDROID:

Android has broken into our world due to its open source license agreement. It is a LINUX based operating system which allows the user to modify its operating system software according to his/her desire. The main advantage is that user can creatively modify or create applications to enhance his/her OS.

Another important aspect of Android is that due to its open handset alliance and open GL, any hardware peripherals can be programmed individually according to their needs.

For instance: One of the hardware units that are found in Smart phone is Gyroscopes, which can sense the gravity. This can be either used to change the orientations of the mobile from portrait to landscape (or) to steer a vehicle in a racing game depending upon the applications developed.

V. ANDROID ARCHITECTURE:



Fig 1.2 Android system Architecture

Any app can be developed according to the above architecture and can be used to control any hardware peripherals.

VI. METHODOLOGY:

STAGE I:

The ARM processor is placed in the main circuit board. Each of its Chip-select pins is connected to the circuits of the appliances via the relay circuits provided by us. The ARM processor is programmed in embedded C programming language and the code is burnt using KIEL MICROVISION software. For this purpose GPIO pins are used. These pins tracks the appliances condition whether it is ON or OFF.

STAGE II:

The next step is developing an Android application. The application interface consists of an android app which contains toggle switches and denoting the corresponding appliance or relay.

An application is developed in Android platform using ECLIPSE IDE development software / ADOBE FLASH BUILDER. The source code is written and the interface file .apk is generated and installed in user's android mobile.

STAGE III:

On the other side the ARM processor is connected through Ethernet connection via RJ45 cable IEEE 802.3. This ensures the ARM processor is in data connection as the data pins are connected to the relay circuits of appliances. The IP of user's mobile phone is configured according to the IP of ARM processor. When the user opens the applications and begins to interact with the toggle switch provided, the underlying code is debugged by the ARM processor and the corresponding appliance is controlled. Every code is unique and it is matched

Since the ARM processor is operated at 3.3V, and can be made to operate in INTERRUPT mode, less power is consumed. The main advantage is that the user can control his/her appliance anywhere irrespective of distance since it uses standalone connection using 3G and Ethernet IEEE 802.3.

LOGIC DIAGRAM:

The below mentioned diagram shows the logic connection of how everything is connected. The main advantage is that it can also be done using ZIGBEE module in the case of user doesn't use Ethernet connection.

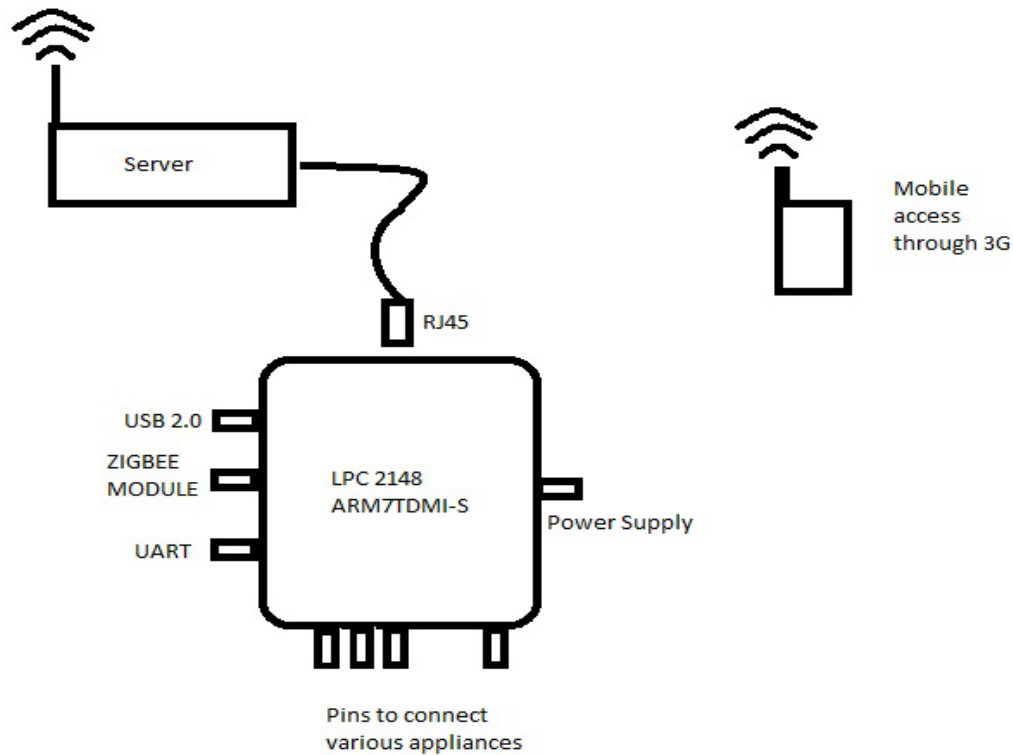

VII. FUTURE ENHANCEMENTS:

The Proposed methodology can be enhanced by porting the ANDROID OS in ARM processor. And it can perform more enhanced tasks like notifying the user about any danger.

It can be implemented in retail shops and universities and any other public sectors where one can easily check up their appliances.

VIII. CONCLUSION:

Thus the traditional method of controlling relays through GSM module by typing message and receiving message through SMS can be smartly changed by our proposal, where user can control just by using a simple application.

IX. CURRENT WORK PROGRESS:

Currently we are working keenly in developing an Android app. This is the main task for us since the app should generate different codes for each toggle switch interface.

ARM processor porting will be completed before 25 and the project is expected by us to get completed by 1st of March 2013.

REFERENCES:

1. Vance, Ashlee (27 July 2011). "[Steve Perlman's Wireless Fix](#)". *Bloomberg Businessweek*. Bloomberg. Retrieved 3 November 2012.
2. "[UI Overview | Android Developers](#)". Developer.android.com. Retrieved 2012-09-15.
3. "[ARM Cores Climb Into 3G Territory](#)" by Mark Hachman, 2002.